

Feeder/Dispenser

VALUE SERIES

Model V-710DM



We Have Your Solution.™



OVERVIEW

The V-710DM provides the flexibility of automating "jumbo" format gripper arm inserters and ink jet/tabber bases. The V-710DM allows for quick and easy installation onto most major brands of vacuum/non-vacuum bases and gripper arm inserters. Increases the throughput and reliability of addressing bases.

TECHNICAL DATA

Maximum Product Size:..... 12 W x 12 L in (305 x 305 mm)*
Minimum Product Size: 3.75 W x 3.75 L in (95 x 95 mm)
 Optional: 2.5 W x 2.5 L in (63 x 63 mm)
Min/Max Product Thickness:003-.75 in (.076-19.1 mm)
Belt Speed: 4000 in/min (101,600 mm/min)
Electrical Requirements:..... 115/230vac, 50/60Hz, 3A
Weight: 41 lbs. (18.6kg)
Warranty: Two-year limited

*Optional product size available

APPLICATIONS

- Gripper arm inserters
- Ink jet bases
- Labeling bases
- Tabber bases

FEATURES

- Large capacity hopper - easy two knob adjustment
- Tool-free adjustments for quick setup and changeover
- Variable angle feed belts enhance feeding performance
- Variable speed control for synchronous operation
- Durable lightweight construction
- Easy to learn and operate

DIMENSIONS

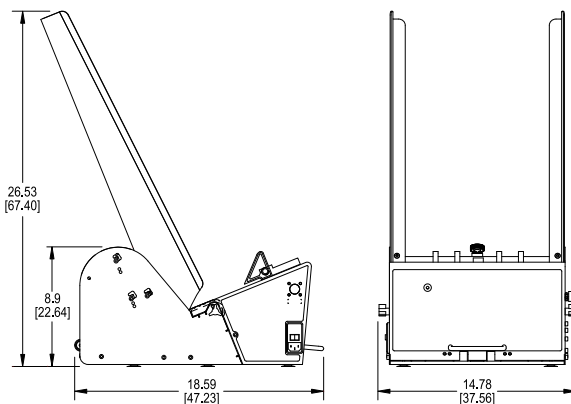

Streamfeeder - Asia : PT. Cakrawala Mega Engineering, Tel : +62 21 2952 6490, +62 812 921 6168, Email : sales@cakrawalamega.com



www.streamfeeder.asia

www.intecprinters.asia

www.industrialmachinerysolutions.com